

Flying-Hobby Company APLUS300

APLUS 300



Aplus 300 Specifications:

Length overall: 480mm

Height (from skids to top of rotor head): 185mm

Width (at widest part of the canopy): 85mm

Main rotor span: 540mm

Tail rotor span: 110mm

Weight: 235grams(kit)

Recommended motor and pinion: Outrunner 3800 kv / 12T

Gear tooth pitch: 64 P

Recommended Battery: 3S Lithium Polymer 800-1500 mah

Flying-Hobby Company APLUS300

Contents

1. Important Notes
2. Assembly
3. Parts and Tools

Thank you very much for buying a Flying-Hobby product. In order to be able to use this product safely, please read this manual before flying the helicopter. Please fly the helicopter safely observing all rules and manners after having fully understood the flight precautions, the unit's capabilities, and the best way to fly it. Be sure to retain the manual for future reference, routine maintenance, and tuning.

Important Notes

- This helicopter is recommended for skilled intermediates and advanced RC helicopter flyers.
- Make sure to read and follow all the instructions in this manual, including all accessories.
- Should any unclarity arise, please confirm with an experienced RC helicopter personnel / instructor before introductory flight.
- Always find an experienced and / or qualified personnel / instructor for per flight inspection.
- Make sure flight vicinity is in an open space; free of crowds, obstacles, and buildings. Failure to abide may cause accidental and potentially hazardous encounters.
- Introductory flight should incorporate only the basic maneuvers (hovering, linear ascensions and descensions), until stick feel is mastered.
- **For stock wood blades don't use over 2200RPM.**

Note

Fly only in safe areas, away from other people. Do not operate RC helicopters within the vicinity of homes or crowds of people. RC helicopters are prone to accidents, failures, and crashes due to a variety of reasons including, lack of maintenance, Pilot error, and radio interference. Pilots are responsible for their actions and damage or injury

Flying-Hobby Company APLUS300

occurring during the operation or as a result of RC helicopter models.

Recommended Equipment (NOT included in kit)

- Radio Control System – 6 channels or More Heli-capable transmitter and / or equivalent. (required)
- Receiver - 6 channels or more
- Gyro -1 pcs 6 g-15 g gyro
- ESC - 25 AMP or More (BEC Support 4 servos)

Pre Flight Checks

1. As a precautionary avoidance to frequency interference (2 different helicopters utilizing the same frequency), it is important to keep the remote controllers and helicopters apart for at least a distance of 1.5 mile. In order to prevent accidental encounters from occurring; please make sure the surrounding areas (flight area) are not populated with crowds and / or buildings (open space). Open space vicinity should be at least 100 feet in all directions.
2. Make sure the battery is completely charged. Read carefully the suggested charging time and maintenance procedures listed in the instruction manual. Attempted flight without a fully charged battery will result in an unexpected loss of power, directional control, and / or costly accidental crashes, and etc. Emptying the battery after usage will increase its connectivity.
3. You are now ready to turn ON both the transmitter (remote control) and the receiver (located on the helicopter). Make sure the helicopter is placed stably leveled on the ground before commencing. Always turn on the receiver first, prior to turning on the transmitter (remote control).
4. Test and confirm the directional controls are working properly. Try moving the directional stick and study the resulting effects of the helicopter. If no resulting movement is noticed when moving the directional stick, do not attempt flight; as either the helicopter or remote control may be defective.

Flying-Hobby Company APLUS300

5. Before test-fly, better tie the heli model to a fixed place under safe conditions, and then gradually increase its power, making it perform various movements frequently till at least one battery is used up in order to make the parts fit smoothly. After that, check the heli to see if there is any screw loose and make sure all the screw are tightly fixed.

The following lists the most recommended methods for a beginner to commence their journeys into remote control flying realm. (Listed in order of importance)

1. Find an experienced Instructor – mostly can be found at your local hobby store.
2. Join a RC club in your nearby area – can be found through the internet, hobby stores, parks, and friends (word of mouth).
3. Practicing the “Frog Jump” (will be explained later).

Never start flying without implementing any or all of the recommended methods listed above.

“Frog Jump”

1. Make sure you are standing directly behind the helicopter before any attempted flight.
2. Slowly introduce power to the helicopter in a continuous and stable pace.
3. Analyze carefully the characteristics of the helicopter. As more power is introduced, the helicopter will begin its ascension progress. Make directional adjustments to counter and insure a linear ascension and descension path.
4. Make sure never to exceed a flying height of over 2 feet! Anything over the recommended height can and may cause major damage to the helicopter if crashed.
5. Upon reaching the recommended maximum height, slowly release and let off on the throttle till landing. Always maintain the helicopter’s plane leveled to the ground.
6. Continually practice this technique until you can masterfully perform linear paths of ascension and descension, as

Flying-Hobby Company APLUS300

well as stationary hovering capabilities.

7. As your skills improve, slowly introduce lateral movements to the helicopter; with your starting point of spot as the final goal (position). Make sure to keep the lateral distances within a 3 feet diameter. Furthering the recommended distance will increase accidental encounters.
8. Once these techniques are mastered, you are now ready to elevate both your helicopter and flying skills to its potential.
9. It's strongly recommended for softened landings, slightly tilt and allow the front part of the landing strut to touch down, followed by the rear half.

Notes

Nearly 90% of crashes, for beginners, are associated with behaviors of nervousness and/or panic. Only about 10% are directly related to mechanical failures.

Repetitive practice is the only way to enhance your skill: developing controls sensitivity, awareness, and understanding.

Regular maintenance is required to keep the Aplus helicopter in optimal and safe flying condition. The model requires precise configuration of the components and setting to be kept by the owner. Maintain regular maintenance on the model to avoid accidents or loss, and optimum performance.

● Main Rotor Checklist

1. Main rotor housing: When the main rotor housing is worn or faulty, there will be obvious vibration and poor flight control. Check the main rotor, main shaft, and feathering shaft for wear or deformity. Replace parts as necessary to eliminate imbalance.
2. O-rings: The O-rings will lose their elasticity over time. This will cause excess play on rotor and cause instability. Replace as needed.

Flying-Hobby Company APLUS300

3. Main rotor holder: When the heli will not fly or reacts sluggishly, even after checking for proper setting of pitch and throttle, check the following items:
▲Bearings ▲Ball bearings ▲Rotor blades ▲Other parts
 4. Check for excess play or gaps between the surfaces, missing or broken parts, or binding or restricted movement, it is important to check for main rotor balance before each flight. Operating the model when out of balance will cause excessive wear and premature failure of parts, possibly resulting in a dangerous situation.
 5. Control arm assembly: Check regularly for cracked, worn, bent or binding control arms and pushrods. Smooth movement of control arms and linkages is required for stable, vibration free flight.
 6. Swashplate: Check for excess slop in the main ball where the main shaft rides on, and slop or looseness among all the metal parts. Swashplate wear will result in poor stability and lack of control during flight. Replace as necessary.
- Fuselage / Chassis
 1. Main shaft bearing: Normal replacement interval for proper operation is between 60-100 flights. If flying 3D or extreme aerobatics often, inspect the bearing more frequently and shorten the interval as necessary.
 2. One-way bearing: One-way bearings have longer lifetimes. Failure is not common. To keep the one-way bearing in good operation, remove it to clean and lubricate after every 50 flights. If the main drive gear is loose, you should replace the one-way bearing.
 3. Drive belt: Aplus uses only top quality, stretch-proof belts. It is however, impossible to prevent the belt from

Flying-Hobby Company APLUS300

stretching or wearing out. Check belt tension regularly, and check for the wear on the teeth. Replace as necessary.

- Linkage Rods and Connecting Parts

During assembly, take special care to keep the connecting parts in smooth operation, and avoid excess play or binding. Failure to do so will result in poor flight stability. The linkage rods and ends will break and wear due to normal usage, crashing, and poor maintenance and environment. Check for wear and proper operation regularly, replace as needed.

- Tail Rotor System

1. Tail rotor control set: Check the tail rotor bearing regularly. If there is excess play or gaps replace immediately. Avoid any binding or improper contact on the tail components and bearings as this will cause excess wear and heat, potentially melting or deforming the tail system.
2. Tail unit assembly: Avoid flying in tall grass or weeds. If grass or weed becomes lodged in the tail rotor unit, it will interfere with the operation, and cause the helicopter to lose control. Always check for foreign objects in the tail and clean them off immediately. Avoid using lubricants on the exposed surfaces of the model as it will attract and collect dirt and debris, and cause failure.
3. Tail rotor housing: Disassemble tail rotor housing for cleaning and maintenance after every 50 flights. If the tail does not operate smoothly or shows any signs of stress or wear, please replace immediately.
4. Tail rotor: Check the tail rotor blades regularly for damage, especially if the helicopter ever strikes the ground while flying, or after hard landings. Damaged tail blades can induce vibration.

Notice: Maintain regular maintenance on the model to avoid accidents or loss.

Flying-Hobby Company APLUS300

Flying-Hobby Company

**Address : Room 5, 5/F ,Cheung Hing Building,
46 Pitt Street, Yau Ma Tei, KLN ,HK**





Tel : 852-36403077

Fax : 852-36403077

Email : fung@flying-hobby.com



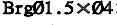
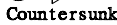
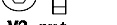

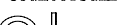
Wed Site : www.flying-hobby.com

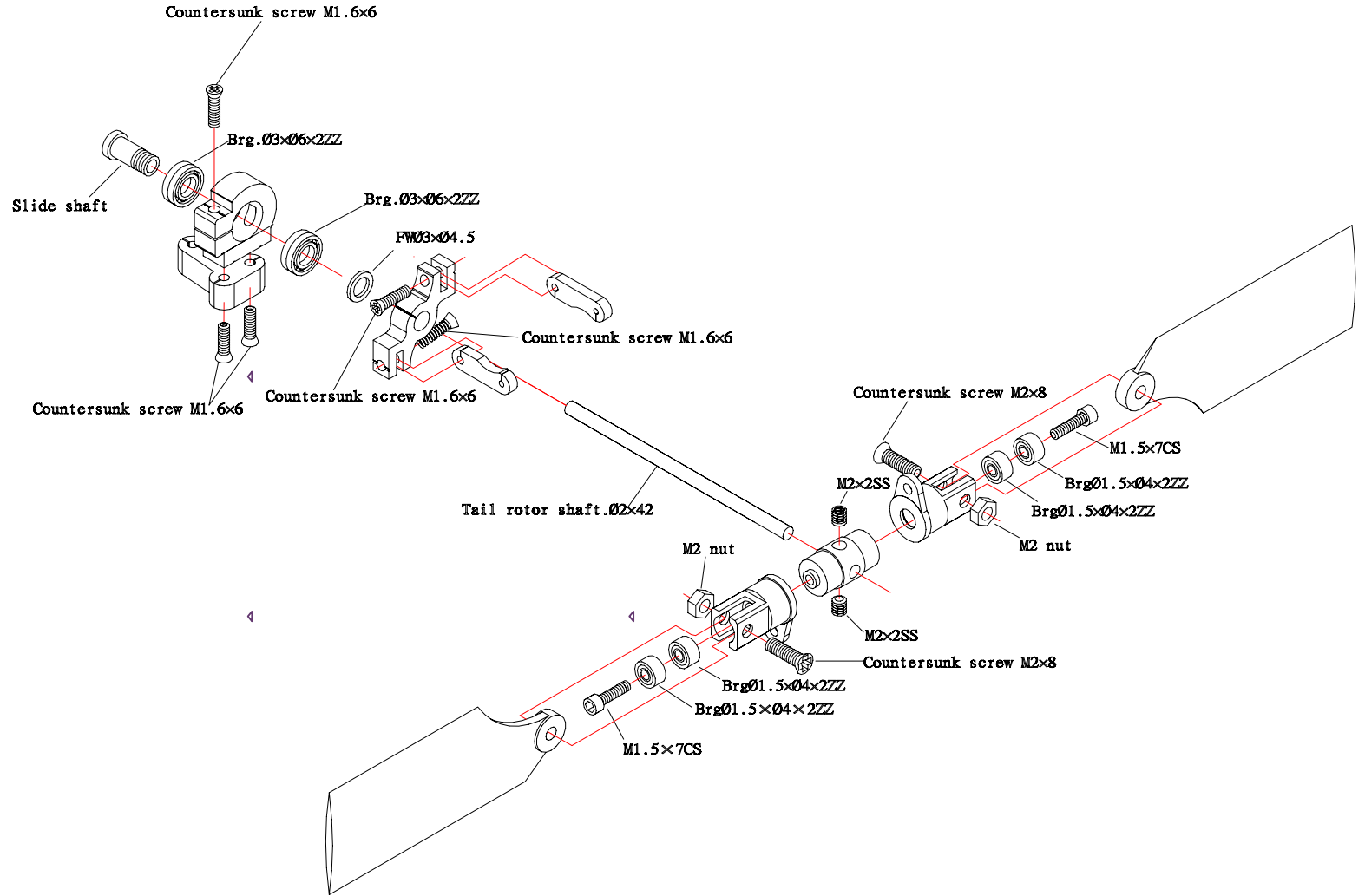
1

	M1.5×7CS	2
	Brg01.5×04×2ZZ	4
	Countersunk screw M2×8	2
	M2 nut	2
	M2×2SS	2
	Countersunk screw M1.6×6	5
	FW03×04.5	1
	Brg.03×06×2ZZ	2



2

		
Countersunk screw M1.6x6		2
		
M1.6 nut		2

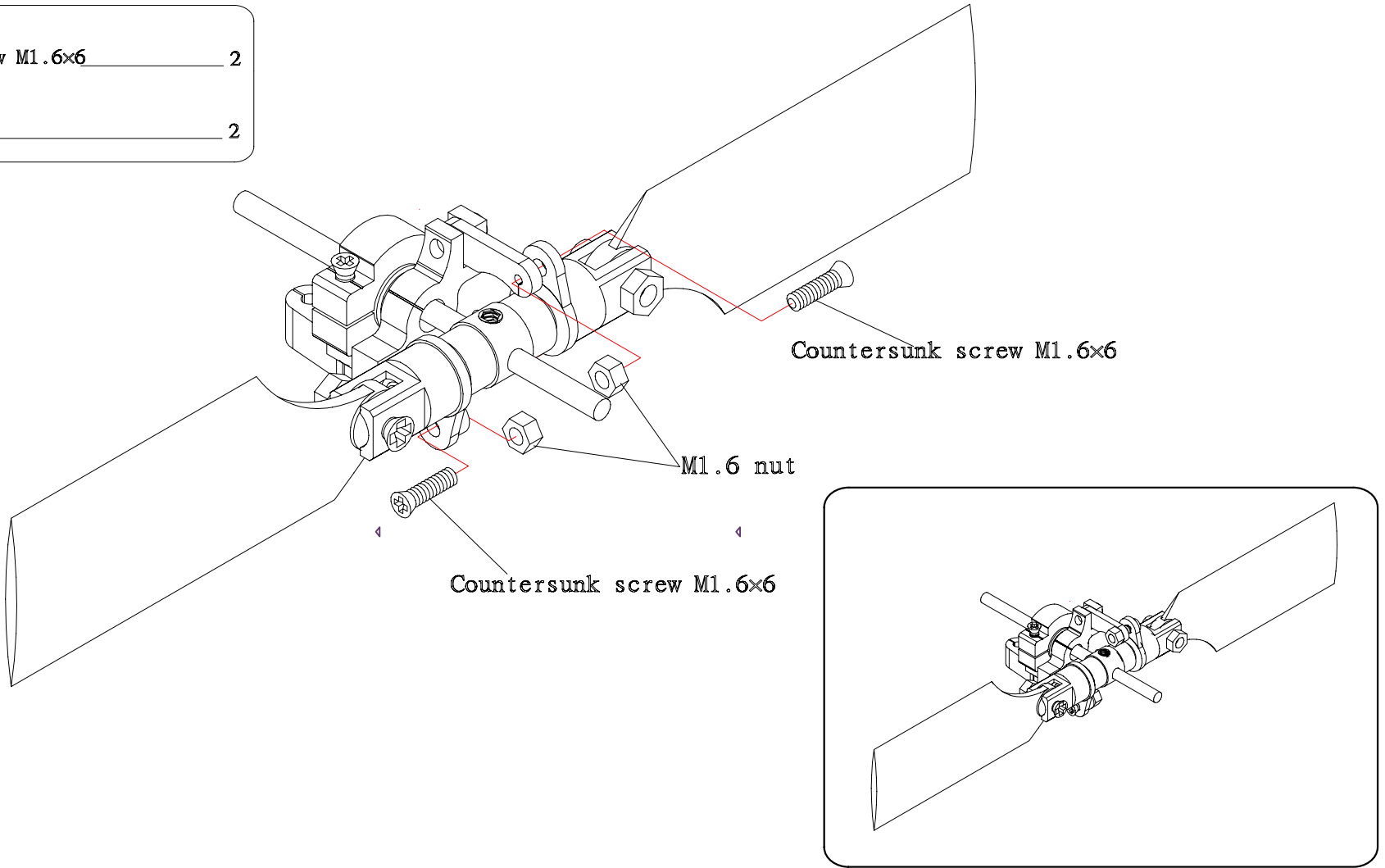



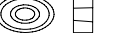

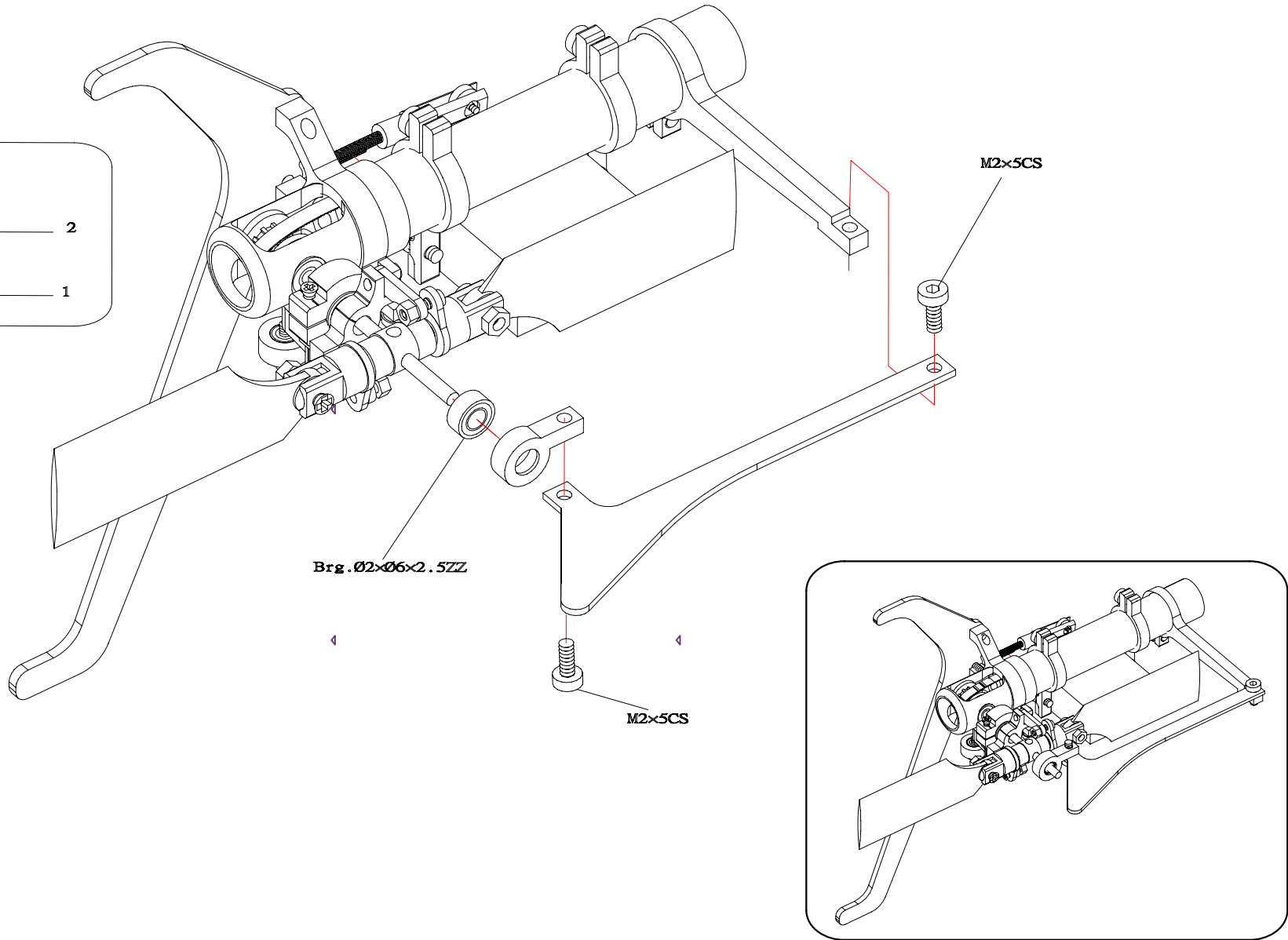



4

	
M2x5CS	2
	
Brg. 02x06x2.5ZZ	1

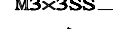
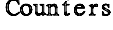

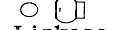
5

	M1.5x7CS	4
	M2x5CS	2
	M2x2SS	12
	M3x3SS	2
	Countersunk screw M1.6x6	6
	Brg.Ø2xØ5x1.5F	2
	Linkage ball	2
	BrgØ1.5xØ4x2ZZ	8
	FWØ2.5xØ1.5	4

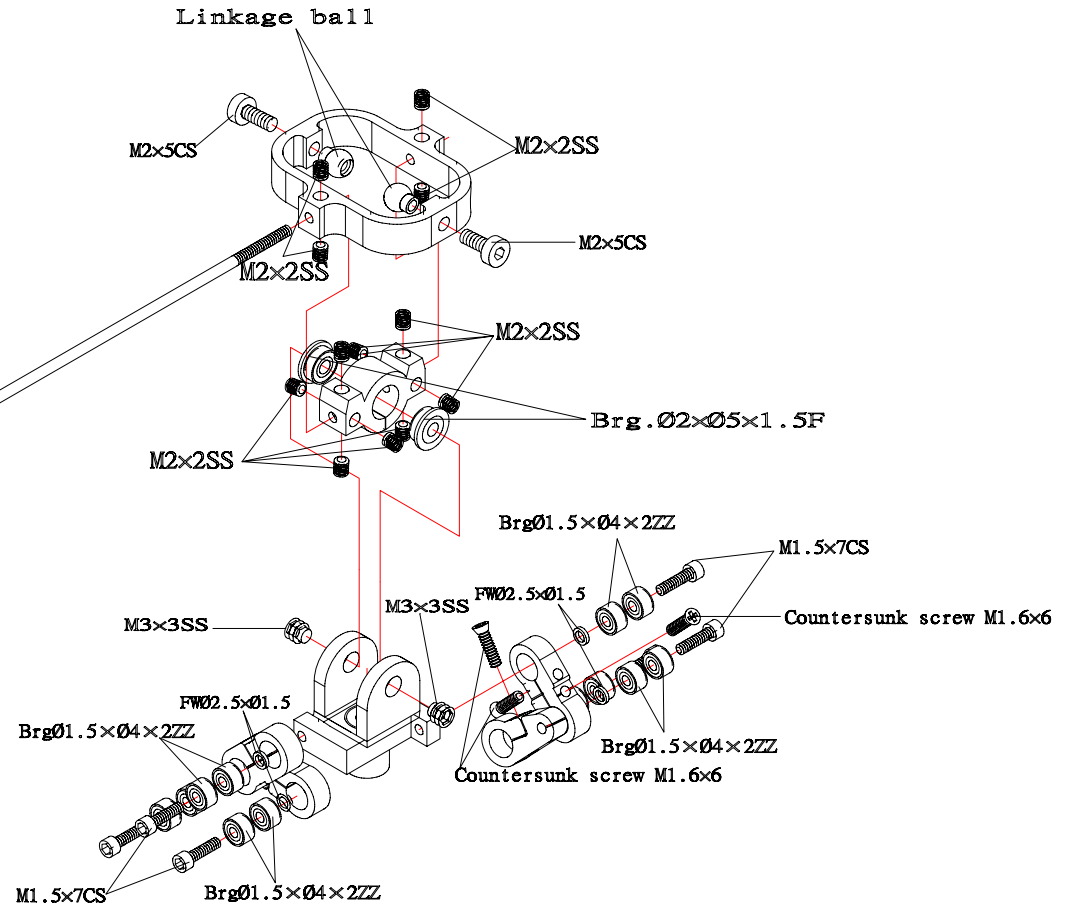

6

	M2x10CS	1
	Countersunk screw M1.6x8	6
	M1.5x7CS	2
	Brg Ø1.5xØ4x2ZZ	4
	FS Ø1.5xØ2.5	2
	Linkage rod M1.5x35	2
	Ball link H13.5	4
	M1.6 nut	6
	M2 nut	1
	O-Ring	8

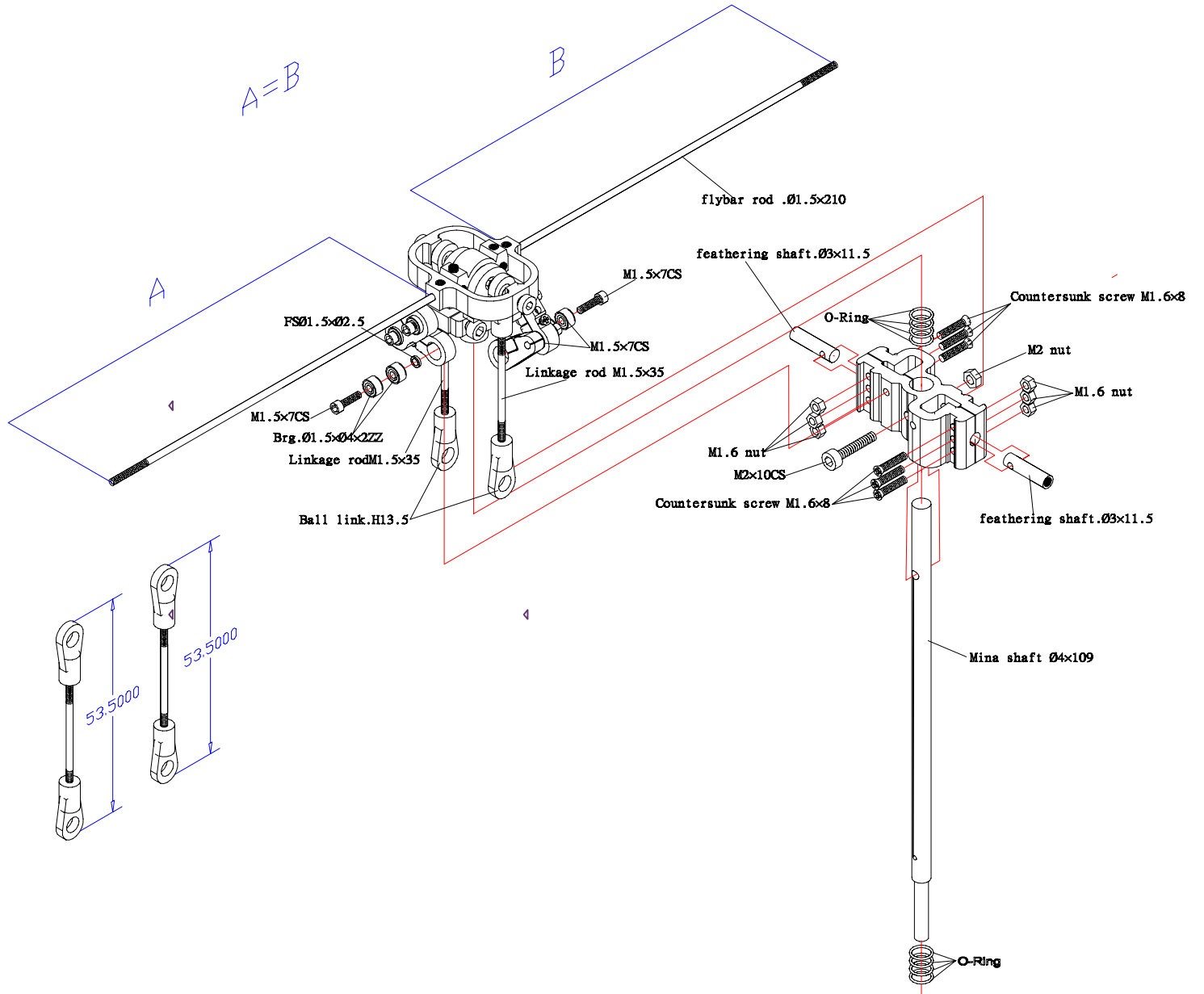

7

 M2x10CS _____

 M2x5CS _____ 2

 M1.5x7CS _____ 2

 M2x2SS _____ 4

 Countersunk screw M1.6x6 _____ 6

 Linkage rod M1.6x10 _____ 4

 Brg.03x06x2.5ZZ _____ 4

 Brg.01.5x04x2ZZ _____ 4

 Hlfbar linkage ball _____ 2



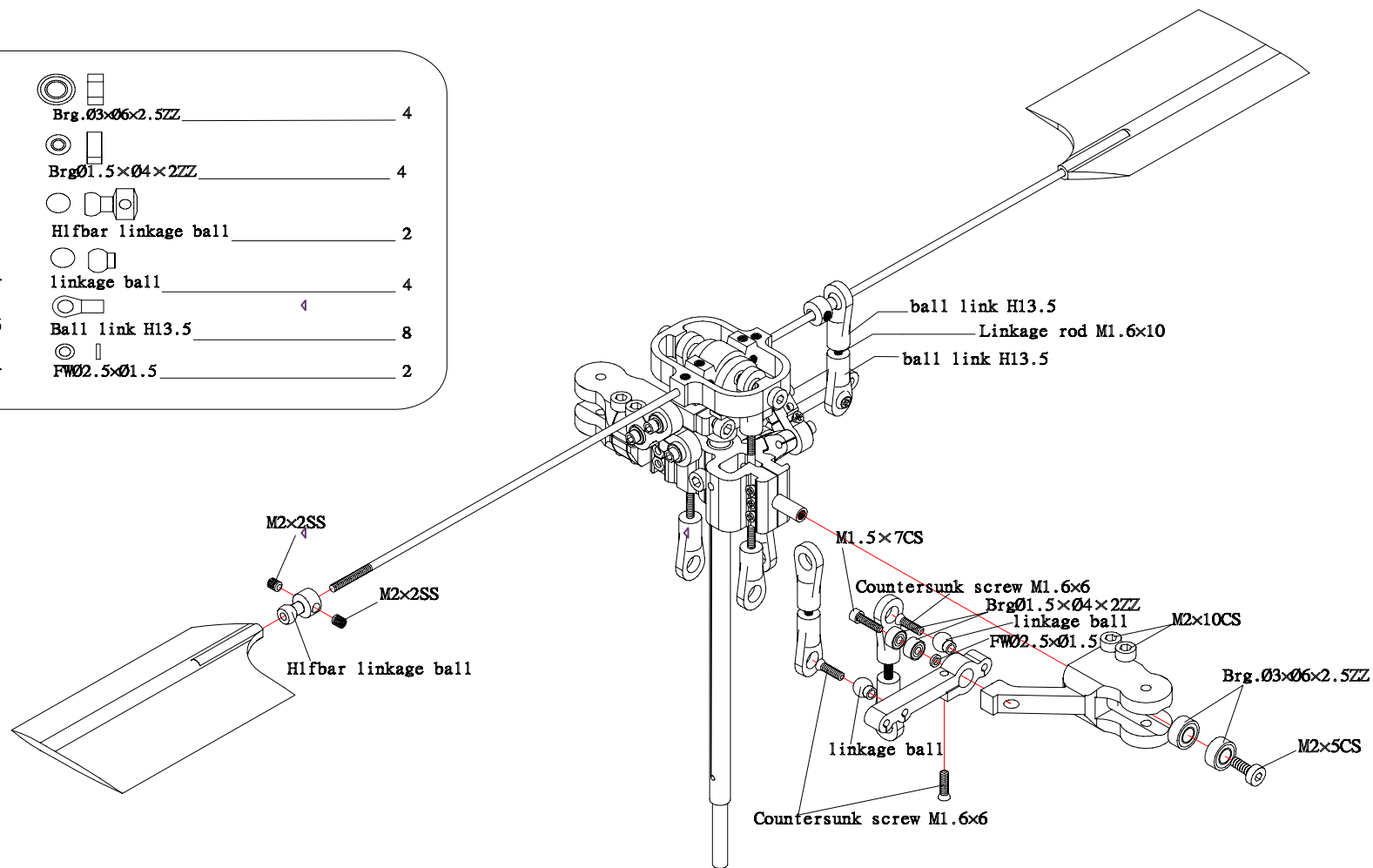

 linkage ball _____ 4

 Ball link H13.5 _____ 8

 FW02.5x01.5 _____ 2



8

		
Countersunk screw M1.6x6		7
		
Linkage ball		7

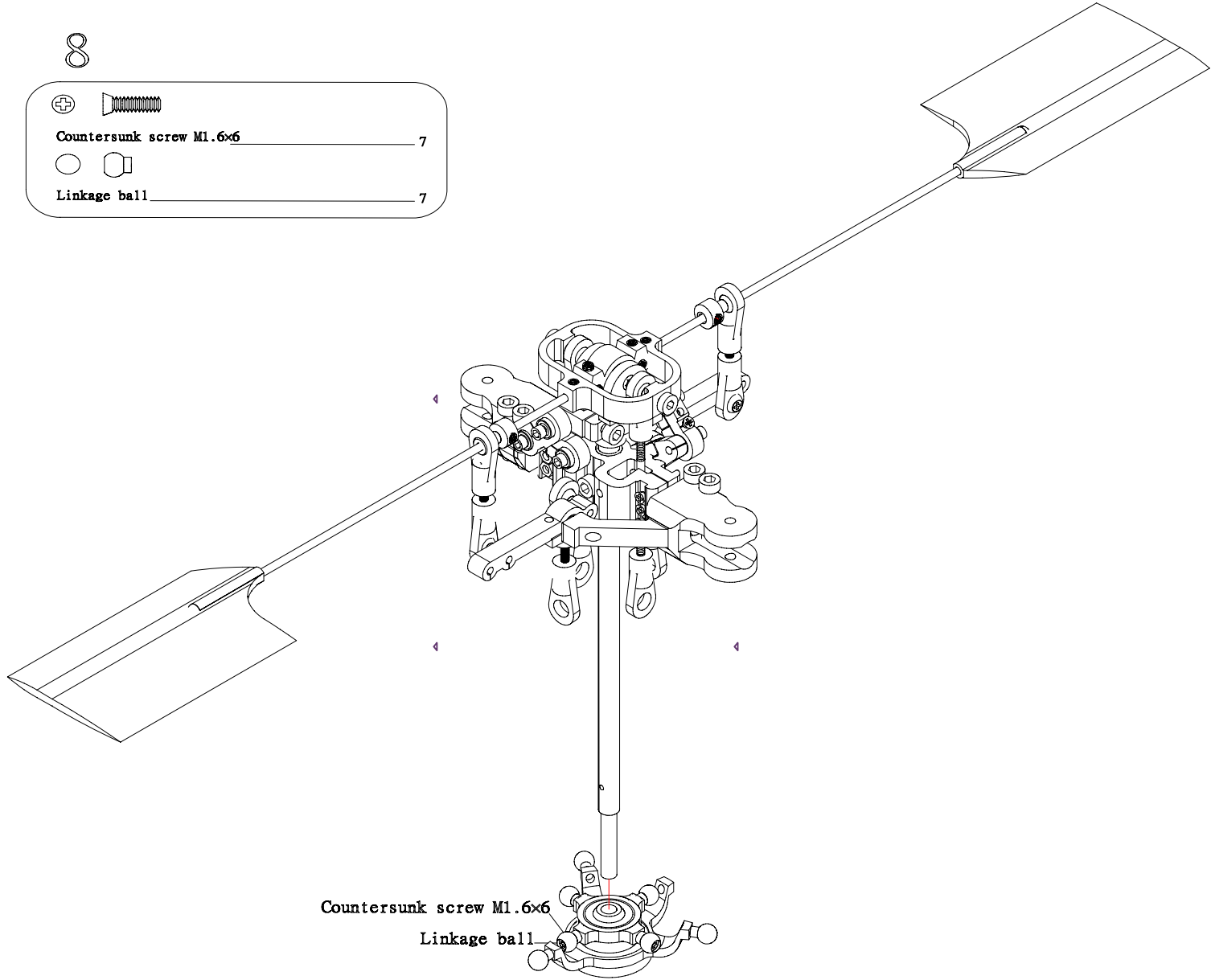





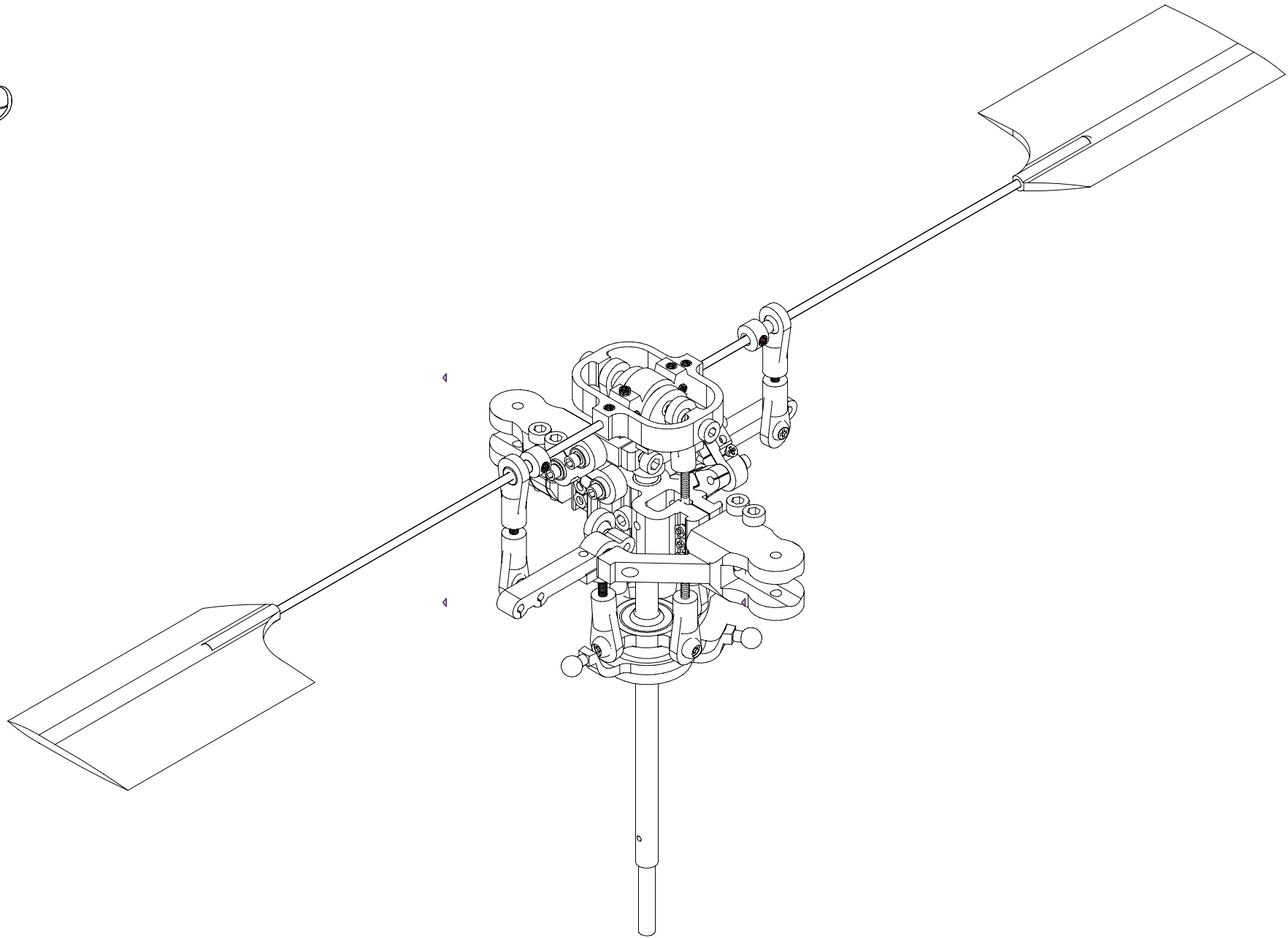

Countersunk screw M1.6x6

Linkage ball



9





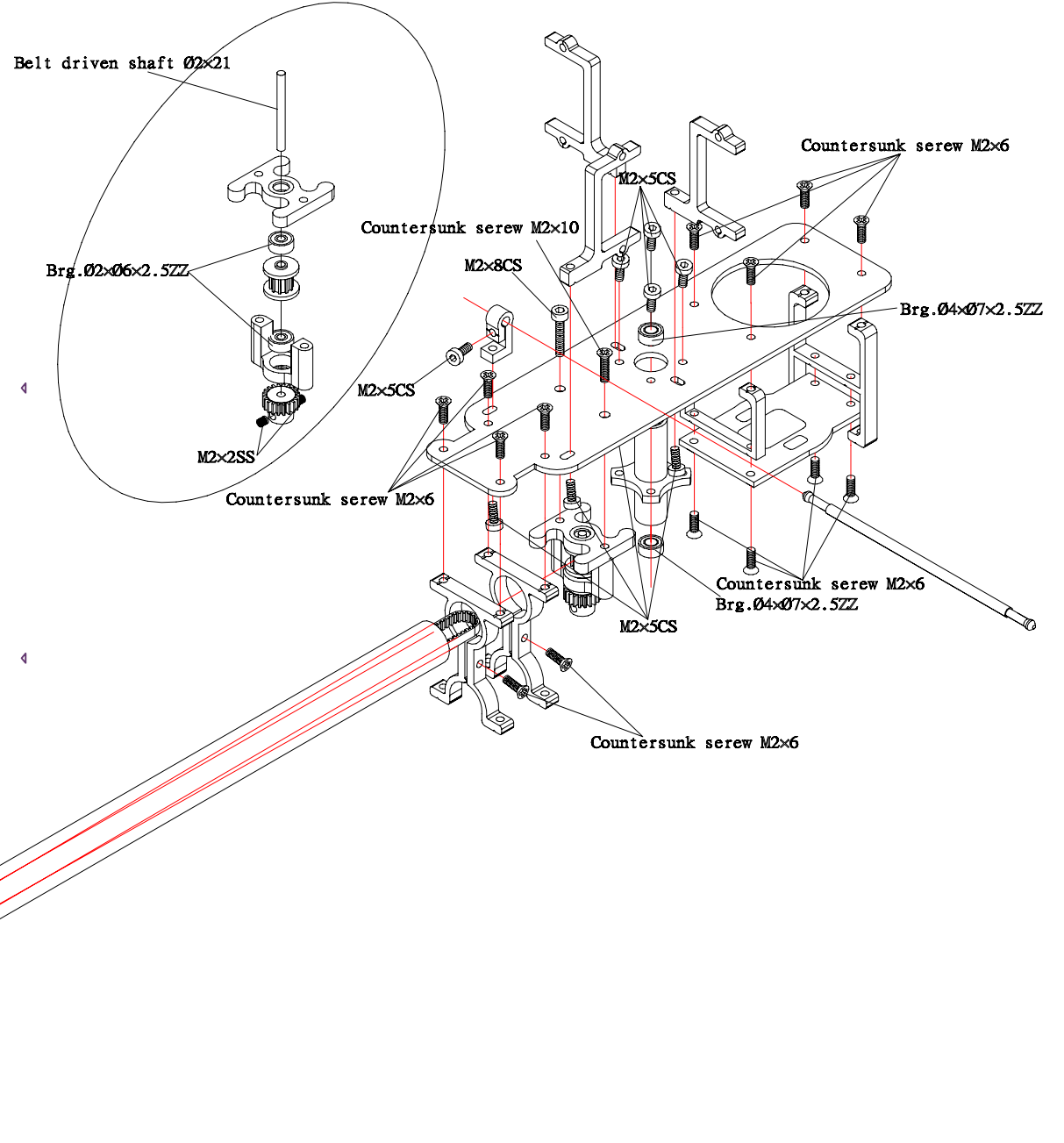

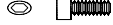

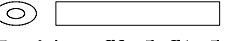
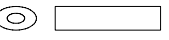

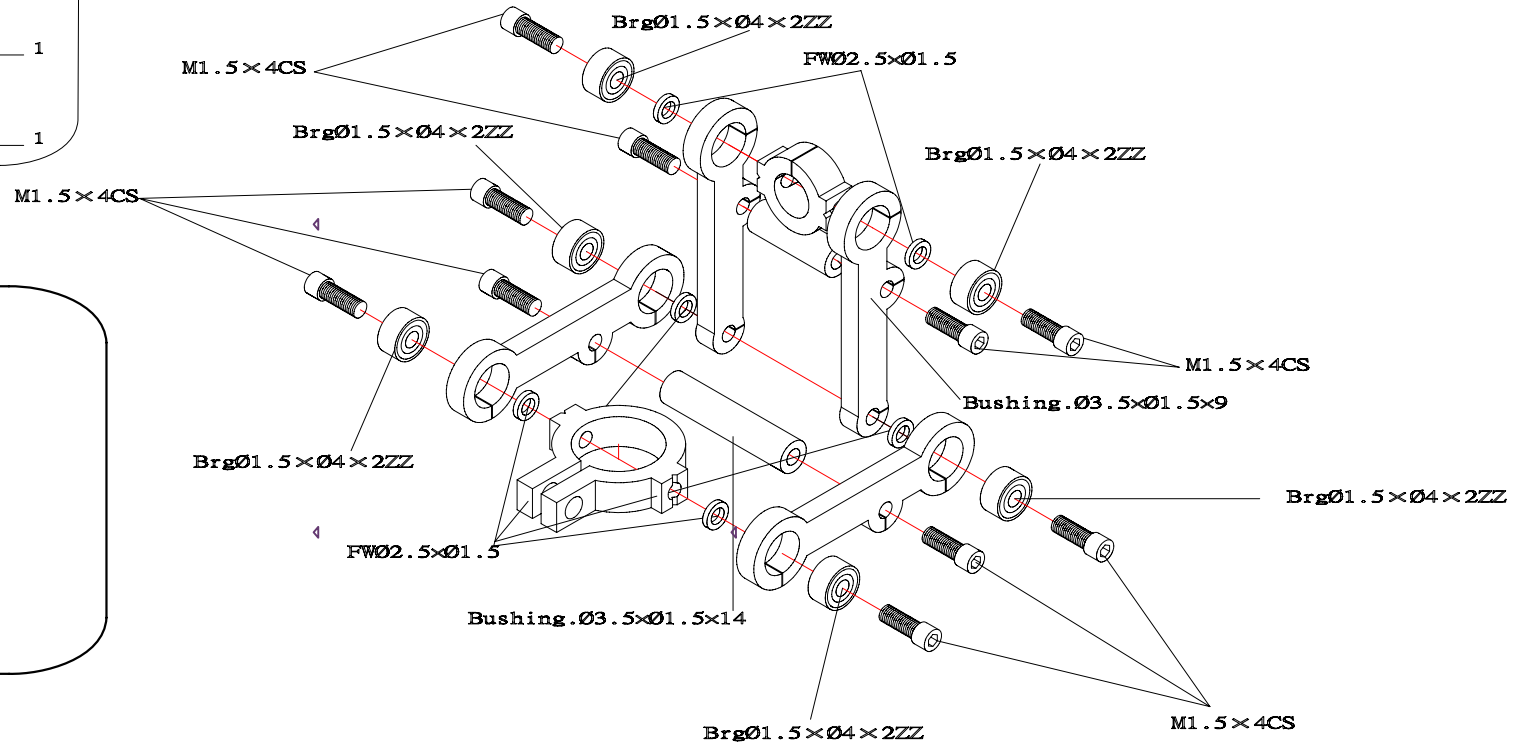
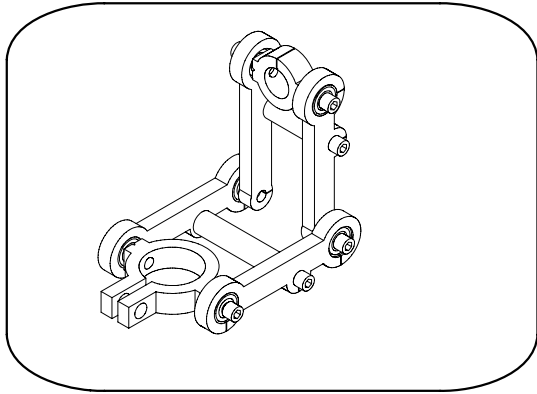

10

	M2x2SS	2
	M2x8CS	1
	M2x5CS	9
	Countersunk serew M2x6	14
	Countersunk serew M2x10	1
	Brg. 04x07x2.5ZZ	2
	Brg. 02x06x2.5ZZ	2



	M1.5×4CS _____	10
	BrgØ1.5×Ø4×2ZZ _____	6
	FWØ2.5×Ø1.5 _____	6
	Bushing.Ø3.5×Ø1.5×14 _____	1
	Bushing.Ø3.5×Ø1.5×9 _____	1





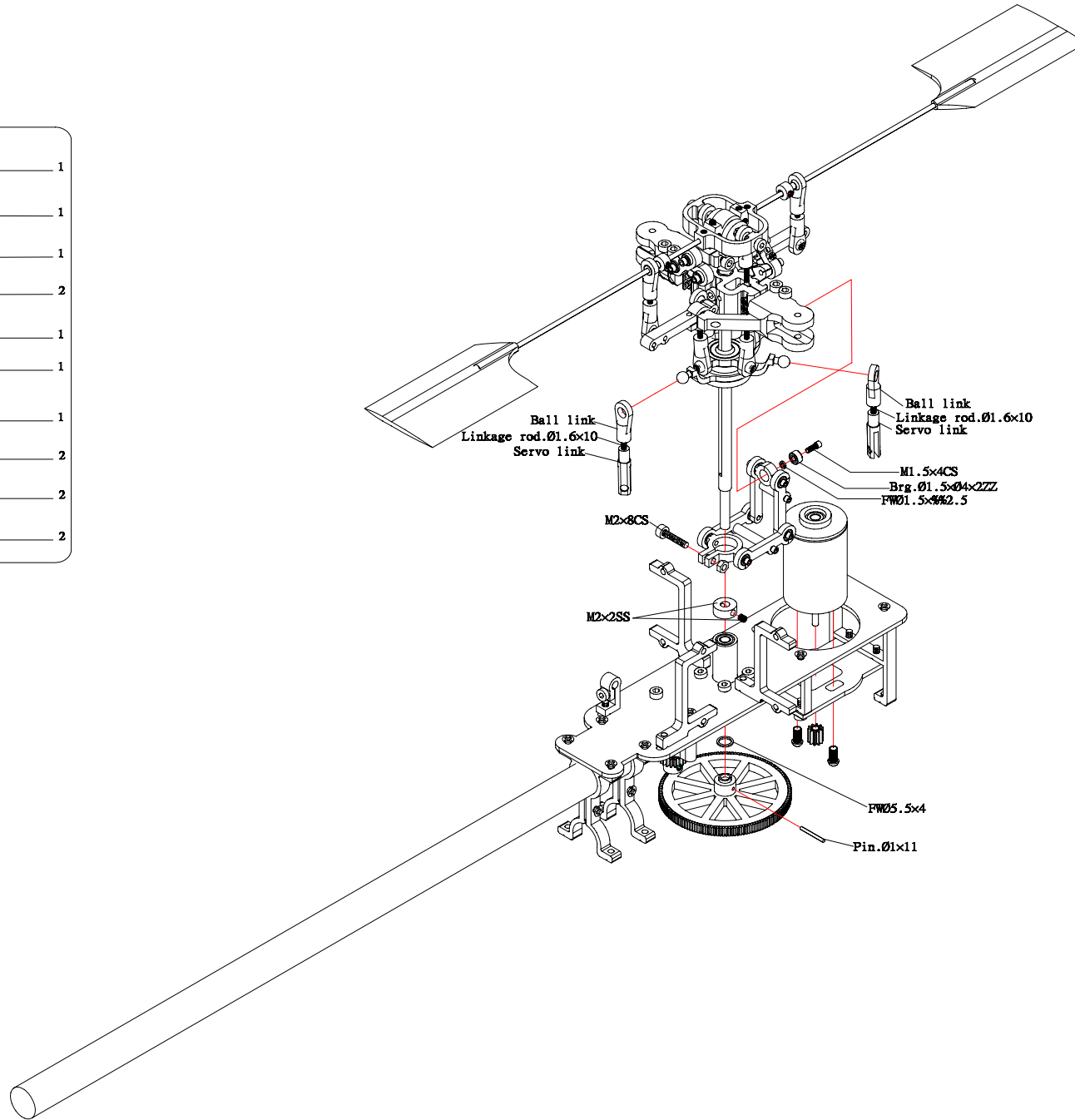

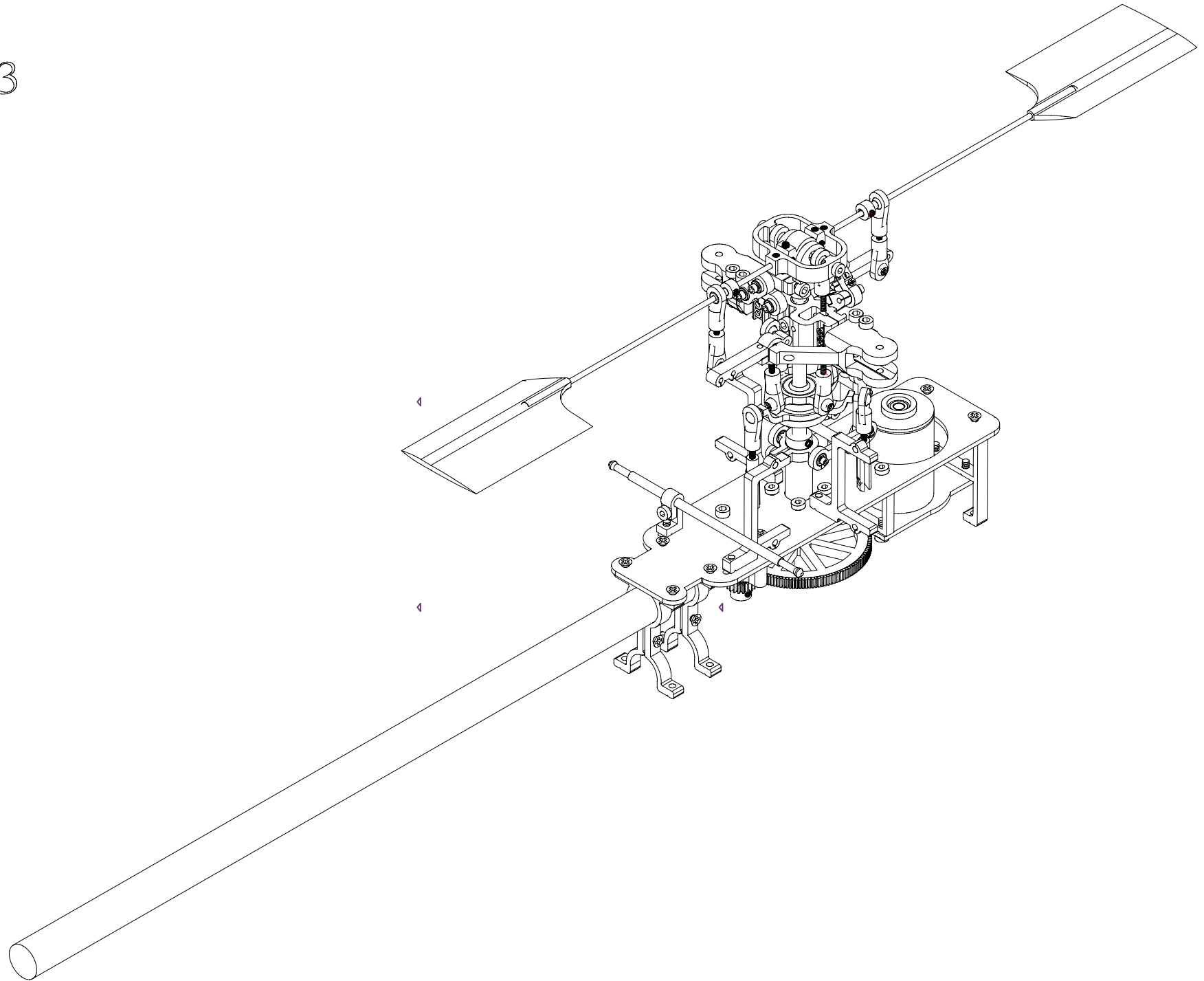

	M2x8CS	1
	M2 nut	1
	M1.5x4CS	1
	M2x2SS	2
	Brg.01.5x04x2ZZ	1
	FW01.5x02.5	1
	FW05.5x4	1
	Linkage rod.01.6x10	2
	Ball link	2
	Servo link	2



13



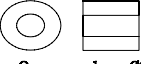

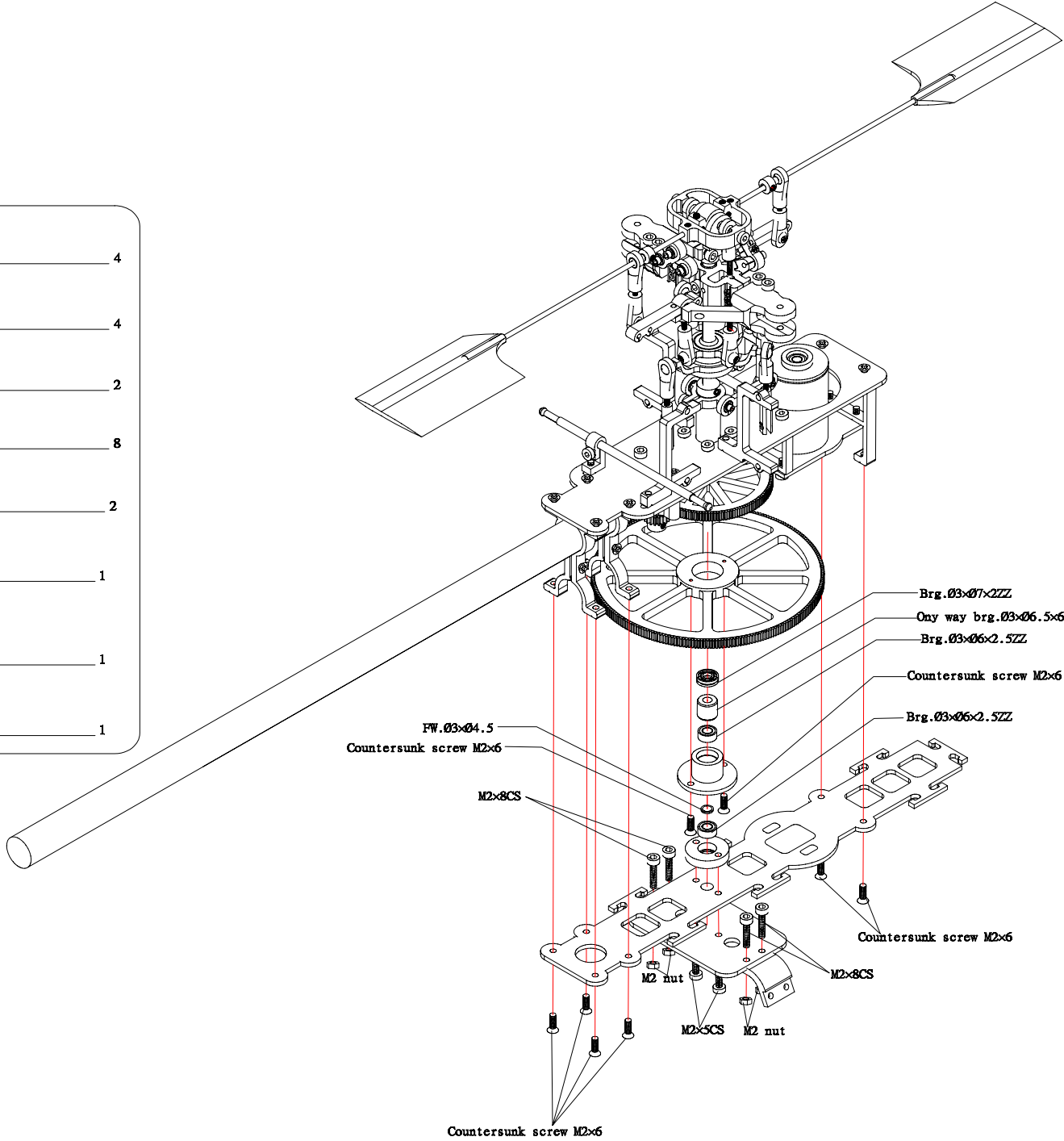

14

	M2 nut	4
	M2x8CS	4
	M2x5CS	2
	Countersunk screw M2x6	8
	Brg. Ø3xØ6x2.5ZZ	2
	Ony way brg. Ø3xØ6.5x6	1
	Brg. Ø3xØ7x2ZZ	1
	FW. Ø3xØ4.5	1



15

		
M2 nut		8
		
M2x10CS		8

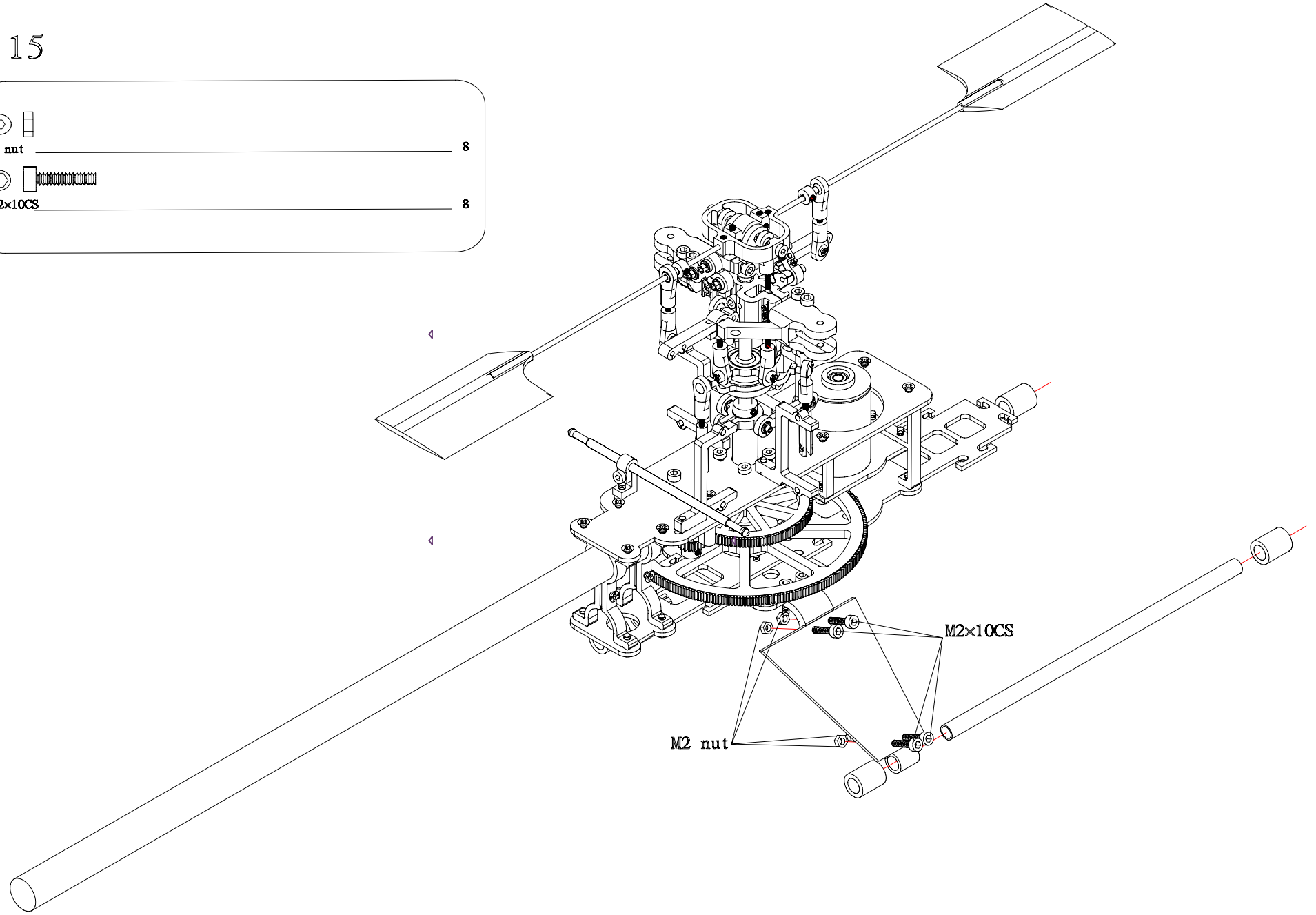

16

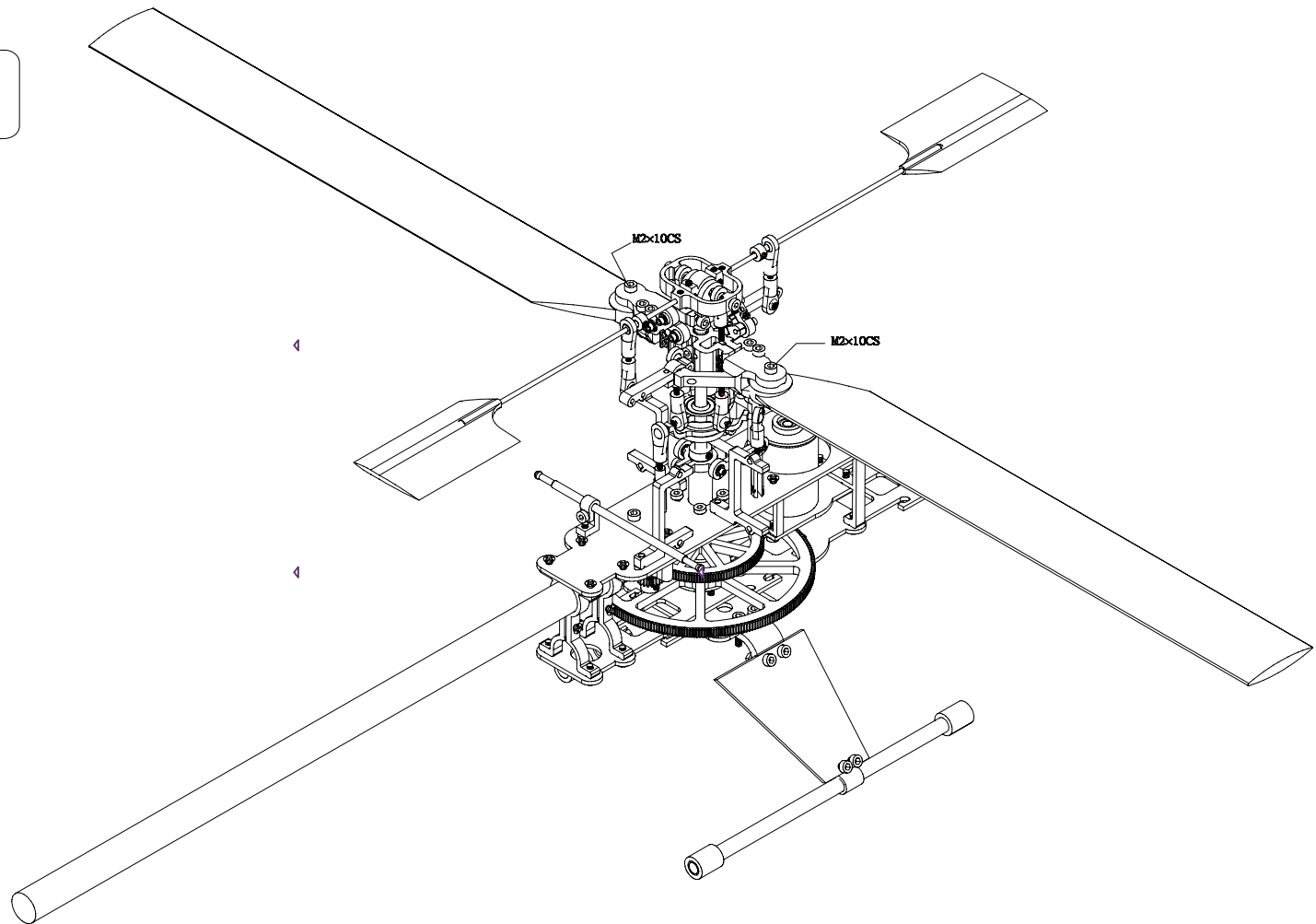
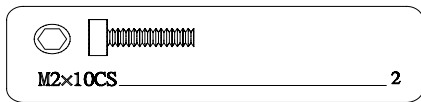

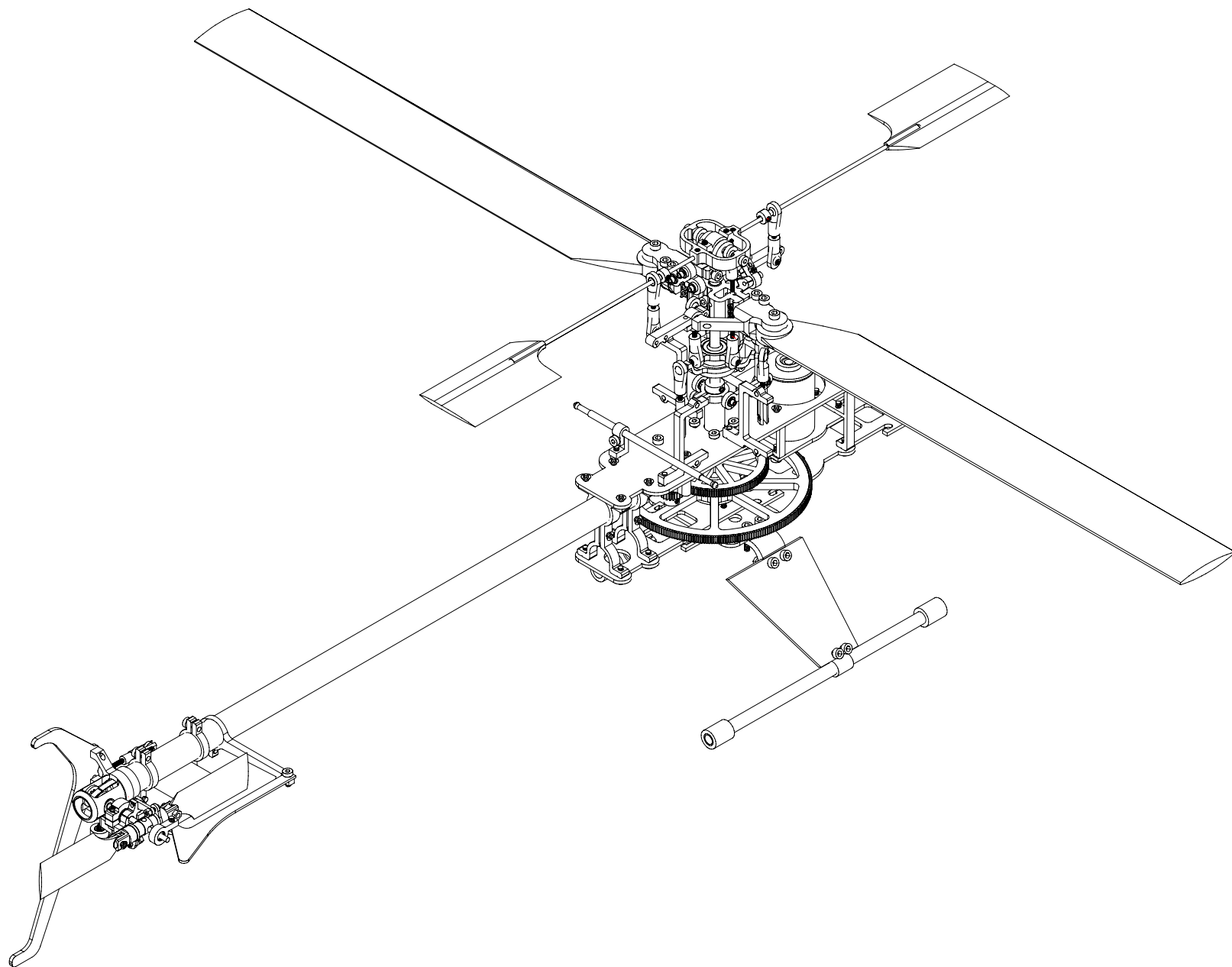

Aplus300 Parts List

 <p style="text-align: center;">AP1004 Ball Link</p>	 <p style="text-align: center;">AP1005 Ball Link</p>	 <p style="text-align: center;">AP1006 Ball Link</p>	 <p style="text-align: center;">AP1007 Servo Ball Link</p>
 <p style="text-align: center;">AP1008 Tail Belt Drive Gear</p>	 <p style="text-align: center;">AP1009 Tail and Front Belt Pulley</p>	 <p style="text-align: center;">AP1010 Main Gear</p>	 <p style="text-align: center;">AP1011 Tail Drive Gear</p>
 <p style="text-align: center;">AP1012 Canopy</p>	 <p style="text-align: center;">AP1013 255 Wood Blade</p>	 <p style="text-align: center;">AP1014 Flybar Paddle</p>	 <p style="text-align: center;">AP1015 Tail Blade</p>
 <p style="text-align: center;">AP1016 Belt</p>	 <p style="text-align: center;">AP1017 Feathering Shaft</p>	 <p style="text-align: center;">AP1018 Swashplate Guide Set</p>	 <p style="text-align: center;">AP1019 Flybar Arms</p>
 <p style="text-align: center;">AP1020 Collective Horn</p>	 <p style="text-align: center;">AP1021 Pivot Support Set</p>	 <p style="text-align: center;">AP1022 Canopy Stand</p>	 <p style="text-align: center;">AP1023 Servo Mount</p>
 <p style="text-align: center;">AP1024 Tail Horizontal Fin Holder</p>	 <p style="text-align: center;">AP1025 Rotor Arm Link</p>	 <p style="text-align: center;">AP1027 Tail Pitch Slider Set</p>	 <p style="text-align: center;">AP1028 Landing Gear Lower Holder</p>

Aplus300 Parts List

 <p>AP1029 Landing Gear Upper Holder</p>	 <p>AP1030 Tail Blade Grips + Hub</p>	 <p>AP1031 Belt Front Pulley Holder</p>	 <p>AP1032 Servo Holder</p>
 <p>AP1033 Frame Back Link</p>	 <p>AP1034 Frame Front Link</p>	 <p>AP1035 Tail Boom Holder</p>	 <p>AP1036 Swashplate</p>
 <p>AP1037 Flybar Ball Set</p>	 <p>AP1038 Rotor Head</p>	 <p>AP1039 Blade Grips</p>	 <p>AP1040 One Way Bearing Set</p>
 <p>AP1041 Main Shaft Stand</p>	 <p>AP1042 Tail Case</p>	 <p>AP1043 CF Boom</p>	 <p>AP1044 CF Vertical Fin</p>
 <p>AP1045 CF Horizontal Fin</p>	 <p>AP1046 CF Landing Gear</p>	 <p>AP1047 CF Landing Gear Upper Part</p>	 <p>AP1048 CF Motor Mount Part</p>

Aplus300 Parts List

 <p>AP1049 CF Frame Upper Part</p>	 <p>AP1050 CF Frame Lower Part</p>	 <p>AP1051 Canopy Stick</p>	 <p>AP1054 Tail Shaft</p>
 <p>AP1055 Retaining Pin</p>	 <p>AP1056 Skid Set</p>	 <p>AP1057 Tail Control Rod</p>	 <p>AP1058 Linkage Rod</p>
 <p>AP1059 Flybar Rod</p>	 <p>AP1060 Main Shaft</p>	 <p>AP1061 Linkage Ball</p>	 <p>AP1076 Bearing 1.5x4x2mm</p>
 <p>AP1077 Bearing 2x6x2.5mm</p>	 <p>AP1078 Bearing 4x7x2.5mm</p>	 <p>AP1079 Bearing 2x5 x1.5mm</p>	 <p>AP1086 2x2mm screw</p>
 <p>AP1087 Hexagon screw driver 0.9mm</p>	 <p>AP1089 Nut 1.6mm</p>	 <p>AP1090 Cross 1.6x6mm</p>	 <p>AP1091 Cross 2x6mm</p>

Aplus300 Parts List

 <p>AP1092 Cross 1.6x8mm</p>	 <p>AP1093 Hexagon 2x5mm</p>	 <p>AP1094 Hexagon 1.5x4mm</p>	 <p>AP1095 Hexagon 2x8mm</p>
 <p>AP1096 Hexagon 2x10mm</p>	 <p>AP1097 O-Rings And Washers Set</p>	 <p>AP1198 Pivot Support Screws</p>	 <p>AP1100 Motor Gear 10/12T for 2.3mm</p>
 <p>AP1101 Motor Gear 10/12T for 2mm</p>	 <p>AM-300L Outrunner kv3800</p>		